

HHM Series Desiccant Dryer

Models HHM5-HHM300

Installation, Operation, and Maintenance Manual

47846571
Revision B
May 2024

Compressed Air Technology Innovation

CONTENTS

1.0 INTRODUCTION	3	7.0 MAINTENANCE AND	
2.0 ABBREVIATED WARRANTY	3	SYSTEM CHECK	16
3.0 RECEIVING AND INSPECTION	4	7.1 SCHEDULED MAINTENANCE	16
3.1 INSPECTION	4	7.2 PREFILTERS AND	
3.2 UNPACKING AND HANDLING	4	AFTERFILTERS	16
4.0 SAFETY AND OPERATION		7.3 PILOT AIR CONTROL SOLENOID	
PRECAUTIONS	5	VALVES AND FILTER/	
4.1 SAFETY PRECAUTIONS LIST	5	REGULATOR	16
5.0 PRINCIPLES OF OPERATION	6	7.4 MUFFLER CHANGEOUT	
5.1 INTRODUCTION	6	PROCEDURE	17
5.2 DRYING CYCLE	6	7.5 ANGLE SEATED PURGE AND	
5.3 REGENERATION CYCLE	6	SWITCHING VALVES	17
5.4 REGENERATION AIR FLOW	6	7.6 DESICCANT CHANGEOUT	
5.5 TOWER RE-PRESSURIZATION	6	PROCEDURE	17
5.6 VALVES	7	8.0 TROUBLESHOOTING	18
5.7 TIMING SEQUENCE	7	9.0 WIRING DIAGRAM	19
5.7.1 TIMING CYCLE FOR -40°F (-40°C)		9.1 HHM 5-HHM 25, ELECTRICAL	
DEW POINT DRYERS	7	SCHEMATIC	19
5.7.2 TIMING CYCLE FOR -100°F (-70°C)		9.2 HHM 40-HHM 300, ELECTRICAL	
DEW POINT DRYERS	7	SCHEMATIC	20
5.8 COMPRESSOR INTERLOCK FUNCTION		10.0 FLOW DIAGRAM	21
(HHM 40 - HHM 300 ONLY)	7	10.1 HHM 5 - HHM 25	21
5.9 ENERGY MANAGEMENT SYSTEM ..	8	10.2 HHM 40-HHM 150	22
5.10 DRYER CONTROLS	8	10.3 HHM 200-HHM 300	23
5.10.1 DRYER ALARMS	9	11.0 ANGLE VALVE REBUILD PARTS	24
5.10.2 DRYER COMMUNICATION RS485		12.0 ENGINEERING SPECIFICATIONS	25
(HHM 40 - HHM 300)	9	12.1 ENGINEERING DATA (-40°C)	25
5.10.3 CONTROLLER DISPLAY		12.2 ENGINEERING DATA (-70°C)	26
SCREENS	10	13.0 INTRODUCTION	27
6.0 INSTALLATION AND START-UP	12	14.0 MODBUS	27
6.1 APPLICATION AND		15.0 DESICCANT DRYER	
CHECK ANALYSIS	12	INFORMATION	28
6.2 LOCATING AND MOUNTING	12		
6.3 PIPING	13		
6.4 FILTRATION	13		
6.5 ELECTRICAL CONNECTION	13		
6.6 DEW POINT MONITOR			
(EMS OPTION)	13		
6.7 START-UP PROCEDURE	13		
6.8 DRYER SHUT-DOWN			
SEQUENCE	15		

1.0 INTRODUCTION

Hankison Heatless Desiccant Dryers are designed to adsorb moisture from compressed air. The dryers are constructed with two towers that alternate between online (drying) and offline (regenerating modes) in order to yield a continuous stream of dry air at the dryer's outlet. Each tower contains desiccant beads.

During normal operation, wet air passes through the online tower and water vapor from the air is adsorbed (collected) on the desiccant beads. While air is being adsorbed in the online tower, the moisture on the desiccant in the offline tower is removed by a process called desorption (regeneration). After an initial rapid depressurization, a portion

of dried air from the online tower passes over the desiccant bed and carries the moisture off the bed and out the dryer's exhaust.

The continuous, alternating process of adsorption and desorption is controlled using a timer that switches the towers in a specific timed sequence. Very dry compressed air dew points are achieved through the continuous switching and operation of this dryer. **Hankison** offers dryers to provide either -40°F (-40°C) or -100°F (-70°C) pressure dew point outlet air.

2.0 ABBREVIATED WARRANTY

Hankison heatless desiccant dryer products are warranted to be free from defects in material and workmanship for a period of 12 months from the original date of shipment from the factory. To allow the warranty to be in effect for 12 months from the date of equipment start-up, the Warranty Registration Card must be completed and returned to **Hankison**.

Alternately, the Warranty Registration Card may be completed online at www.Hankisonair.com. The total warranty period cannot exceed 18 months from the original date of shipment from the factory.

Equipment must be installed and operated in accordance with **Hankison**'s recommendations.

Hankison liability is limited to repair of, refund of purchase price paid for, or replacement in kind at

Hankison's sole option during the warranty time period stated above. IN NO EVENT SHALL **Hankison** BE LIABLE OR RESPONSIBLE FOR INCIDENTAL OR CONSEQUENTIAL DAMAGES, even if the possibility of such incidental or consequential damages has been made known to **Hankison**. In addition, the usual maintenance and replacement type products are not covered by this warranty. See SECTION 7.

The warranties expressed above are in lieu of and exclusive of all other warranties. There are no other warranties, expressed or implied, except as stated herein. There are no implied warranties of merchantability or fitness for a particular purpose, which are specifically disclaimed.

3.0 RECEIVING AND INSPECTION

3.1 INSPECTION

Upon receiving your **Hankison** desiccant dryer, inspect the unit closely. Evidence of rough handling should be noted on the delivery receipt, especially in the case where the dryer is not going to be uncrated immediately. Obtaining the delivery person's signed agreement to noted damages will facilitate submission of insurance claims.

Contact your local sales office to obtain an RMA claim to initiate the return process (if required).

3.2 UNPACKING AND HANDLING

WARNING

Under no circumstances should any person attempt to lift heavy objects without proper lifting equipment (i.e. crane, hoist, slings or fork truck). Lifting any unit without proper lifting equipment can cause serious injury.

Refer to labels on the dryer for the appropriate means for lifting or moving the dryer. When lifting the dryer, ensure that no stress is applied to the piping or the valves. Refer to SECTION 6.2 for locating and mounting of the dryer.

The dryer can be rigged using the forklift rails (See Figure1) that are located on the bottom of the feet assembly. Use care when inserting fork lift tongs beneath these rails to avoid damage to piping at the rear of the dryer.

Figure: 1

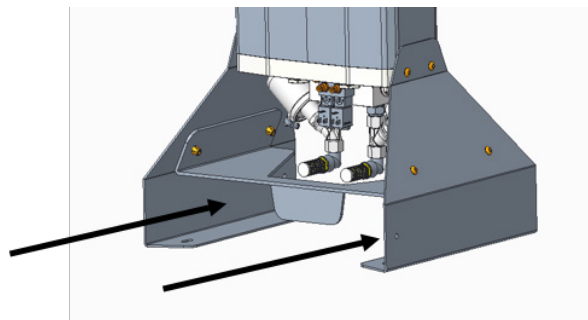

4.0 SAFETY AND OPERATION PRECAUTIONS

4.1 SAFETY PRECAUTIONS LIST

Because an air dryer is pressurized and contains mechanical parts, the same precautions should be observed as with any piece of machinery of this type where carelessness in operation or maintenance is hazardous to personnel. In addition to the many obvious safety rules that should be followed with this type of machinery, the safety precautions as listed below must be observed:

1. Only qualified personnel shall be permitted to adjust, perform maintenance or repair this air dryer.
2. Read all instructions completely before operating unit.
3. Pull main electrical disconnect switch and disconnect any separate control lines, if used, before attempting to work or perform maintenance on the unit. Use proper lockout/tag out procedures.
4. Do not attempt to service any part while dryer is in an operational mode.
5. When servicing this dryers, do not attempt to remove any parts without first relieving the entire air system of pressure.
6. Do not operate the dryer at pressures in excess of its rating.
7. Inspect unit daily to observe and correct any unsafe operating conditions.
8. Dryer must be de-pressurized before servicing.

WARNING

“WARNING” is used to indicate a hazardous situation which has some probability of death or severe injury. Warning should not be considered for property damage accidents unless personal injury risk is present.

CAUTION

“CAUTION” is used to indicate a hazardous situation which may result in minor or moderate injury.

NOTICE

“NOTICE” is used to indicate a statement of company policy as the message relates directly or indirectly to the safety of personnel or protection of property. Notice should not be associated directly with a hazard or hazardous situation and must not be used in place of “DANGER,” “WARNING,” or “CAUTION.”

NOTICE

The user of any air dryer manufactured by Hankison, is hereby warned that failure to follow the included Safety and Operation Precautions can result in personal injuries or equipment damage. However, Hankison does not state as fact, nor does it mean to imply, that the preceding list of Safety and Operation Precautions is all inclusive, and further, that the observance of this list will prevent all personal injuries or equipment damage.

5.0 PRINCIPLES OF OPERATION

5.1 INTRODUCTION

As described in SECTION 1, the dryer is used to remove water vapor from compressed air by diverting air flow alternately between two towers that are filled with desiccant material. While one tower processes the compressed air stream by adsorbing water vapor, the opposite tower is regenerated by desorbing the water vapor accumulated in the previous cycle and venting it to atmosphere. Refer to SECTION 10, FLOW DIAGRAM for a visual representation of the drying and regenerating cycles.

Inlet flow to the dryer is directed to the bottom manifold and the outlet flow exits through the upper manifold. The manifolds are comprised of both pneumatically actuated valves and check valves that direct compressed air flow through the dryer.

5.2 DRYING CYCLE

Saturated compressed air enters the dryer and is directed to the appropriate drying tower by the corresponding inlet flow valves. The inlet flow valves are normally-open and one of the valves will be actuated closed to direct the flow of compressed air to the designated drying tower. It is important to note that only one inlet valve is closed during this process. The FLOW DIAGRAM in SECTION 10 depicts the scenario where the left tower is being regenerated and the drying process is occurring with the right tower. In this example, wet compressed air enters the dryer and is directed to the right tower for drying when the left tower valve is actuated to a closed position. The normally-closed right tower purge valve is closed while the left tower purge valve is actuated to an open position during this period. As the compressed air flows through the desiccant material on the right tower, removal of water vapor from the air stream begins to occur through adsorption.

5.3 REGENERATION CYCLE

Previously adsorbed moisture, removed from the process stream, gets stripped or desorbed from the desiccant material in the regeneration process. The first stage of regeneration is tower depressurization. After the inlet Flow Valves are switched to divert air flow away from the regenerating tower, the appropriate normally-closed purge valve will be opened and the tower will be depressurized. Through rapid depressurization, a significant portion of the previously adsorbed water vapor is stripped off the desiccant material and exhausted to the atmosphere.

The second stage of regeneration uses a portion of the dry, compressed air expanded to atmospheric pressure to complete the desorption process. As depicted in the FLOW DIAGRAM, the compressed air exits the drying tower and a portion of the air flows through the purge orifice. Once the air has passed through the purge orifice, it expands to atmospheric pressure and continues the regeneration process. Desorption occurs as the desiccant releases water vapor into the regeneration air that is then exhausted through the purge muffler.

Heatless Dryers are equipped with a downstream purge feature as standard. The downstream purge utilizes air from a downstream source to purge the regenerating tower. This feature is useful for applications with downstream (dry) storage tanks, as pulling air from a downstream source can minimize cycling of the air compressor.

5.4 REGENERATION AIR FLOW

To enable the desiccant media within the towers to be thoroughly regenerated and to get proper dryer performance, purge air flow is factory preset. Setting the purge flow too high wastes compressed air and setting it too low results in the dryer not achieving proper dew point performance.

NOTICE

Do not restrict purge exhaust flow in any way. Keep purge mufflers clean. If exhaust air must be piped away from dryer, consult factory for correct pipe sizing and configuration.

5.5 TOWER RE-PRESSURIZATION

Upon completion of tower regeneration, and prior to the inlet flow valves changing position to switch towers, the regenerated tower must be repressurized.

Repressurization is accomplished when the appropriate purge valve closes. Closing the purge valve allows the regeneration air to begin to pressurize the tower.

5.0 PRINCIPLES OF OPERATION

5.6 VALVES

Control air solenoid valves (See Figure 2) are used to actuate the main flow valves and purge valves. The inlet flow valves are normally-open valves, while the purge valves are normally-closed valves. This arrangement permits air to flow through the dryer in the event of power failure. The control air solenoid valves are located on the bottom manifold assembly.

Figure: 2

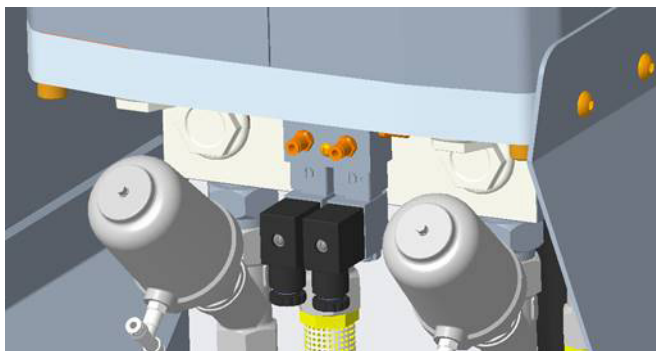

5.7 TIMING SEQUENCE

A Digital Controller controls all dryer timing functions. The timing of **Hankison** -40°F (-40°C) and -100°F (-70°C) dryers is outlined as follows:

5.7.1 TIMING CYCLE FOR -40°F (-40°C) DEW POINT DRYERS

The standard timing cycle for -40°F (-40°C) operation switches the inlet flow valve position every five minutes which alternates the drying tower. At the same time as a tower inlet valve opens, the appropriate tower purge valve opens to depressurize the regenerating tower. Tower regeneration occurs for 4 minutes and 10 seconds, at which time the purge valve closes to initiate repressurization.

5.7.2 TIMING CYCLE FOR -100°F (-70°C) DEW POINT DRYERS

The standard timing cycle for -100°F (-70°C) operation alternates the drying tower by switching the inlet flow valve position every two minutes. At the same time a tower inlet valve opens, the appropriate tower purge valve opens to depressurize the regenerating tower. Tower regeneration occurs for 1 minute and 50 seconds, at which time the purge valve closes to initiate repressurization.

NOTICE

Do not restrict purge exhaust flow in any way. Keep purge mufflers clean. If exhaust air must be piped away from dryer, consult factory for correct pipe sizing and configuration.

5.8 COMPRESSOR INTERLOCK FUNCTION (HHM 40 – HHM 300 only)

The compressor interlock function enables the dryer to reduce the timing of the purge cycle based on compressed air demand. When the function is activated through the TECHNICIAN MODE within the digital controller, the controller monitors the cycle rate of the air compressor load/unload relay. The dryer will need to be field wired to the normally-open contact of the air compressor to allow the controller to monitor the cycle rate. The compressor interlock connections are depicted on the dryer wiring diagram (SECTION 9, Wiring Diagram).

It is important to note that the compressor interlock function is designed to be operated independent from the Energy Management System (EMS) option. For dryers equipped with the EMS option, the compressor interlock must be set to “OFF” in order to activate the EMS function. Setting the compressor interlock to “ON” in TECHNICIAN MODE will disable the EMS function.

For dryers equipped with the EMS option, the compressor interlock function can be used as a backup method to reduce purge air consumption when the dew point monitor is removed for calibration or for service. It is important to note that the performance of the dryer is based on the inlet temperature and pressure conditions along with flow. If the inlet temperature of the compressed air being supplied to the dryer is above 100°F (38°C), the user must exercise caution in order to prevent the desiccant beds from becoming overloaded, possibly requiring the compressor interlock function to be de-activated. Consult the factory for higher inlet temperatures (101°F/38°C - 120°F /49°C). Dryer sizing is affected by increased inlet temperatures.

5.0 PRINCIPLES OF OPERATION

5.9 ENERGY MANAGEMENT SYSTEM

The Energy Management System (EMS) feature is designed to minimize the use of purge air during low flow or low water loading conditions. On -40°F (-40°C) units, a dew point sensor samples the moisture content from the online tower and provides a signal to the controller. This function utilizes a dew point transmitter that monitors the dew point of the air exiting the dryer. Please note that the dew point transmitter should not be installed on a newly started machine until the dryer has operated continuously for a minimum of 24 hours.

5.10 DRYER CONTROLS

The dryer is controlled by a digital controller that includes an illuminated display and keypad, accessible on the dryer main panel.

HHM 5 - HHM 25 Models



CONTROLLER BUTTONS AND KEYS

ON/OFF Button	Press 2 seconds
Set up Menu Button	To enter cycle time setting
UP/DOWN Arrow key	To change cycle time

When the dryer is actively cycling LT or RT and R or D will illuminate to indicate working phase of each tower. The numeric countdown timer indicates seconds remaining in the operating cycle step.

If cycle times need to be adjusted to meet site conditions, a trained service technician must be the one to make the changes.

5.0 PRINCIPLES OF OPERATION

HHM 40 - HHM 300 Models

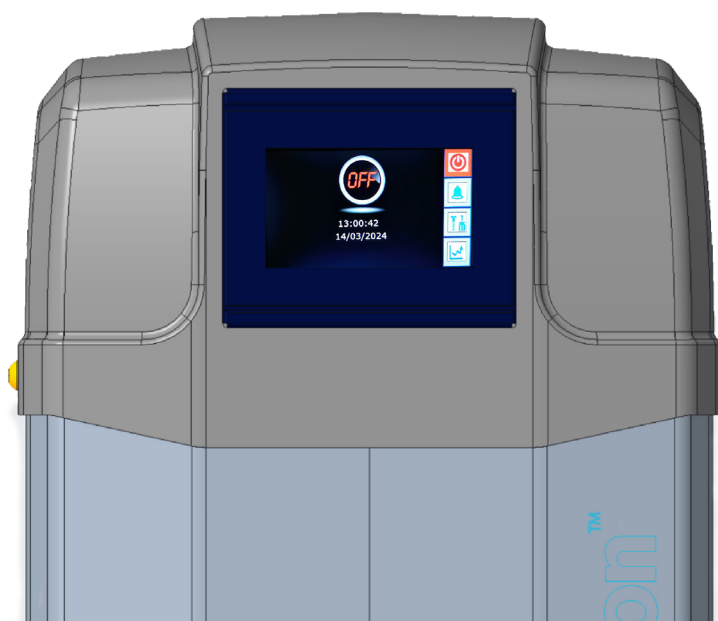

NOTICE

In order to ensure proper tower pressurization, every dryer ON (restart) has 30 seconds delay incorporated into software. Countdown is visible on PLC main screen.

On models HHM 40 - HHM 300 Multiple screens can be viewed. Follow PLC screen to navigate through screens (touch screen).

5.10.1 DRYER ALARMS

HHM 5 - HHM 25 do not offer any alarms.

HHM 40 - HHM 300 offer predefined elapsed time alarms, that can be reset by pressing the "Reset" button.

1. Filter element change - 6 months (or as per the filter maintenance plan)
2. Mufflers - 12 months
3. Dew point sensor - 12 months
4. Valves - 36 months
5. Desiccant change - 48 months

5.10.2 DRYER COMMUNICATION RS485 (HHM 40 - HHM 300)

1. RS485 port
2. RS485 connector signals
 - D+ Tx/Rx+ (B)
 - D- Tx/Rx- (A)
 - T+ Positive Termination
 - T- Negative Termination
 - SG Signal Ground

Refer to MODBUS Communications Guide, Page 28.

5.0 PRINCIPLES OF OPERATION



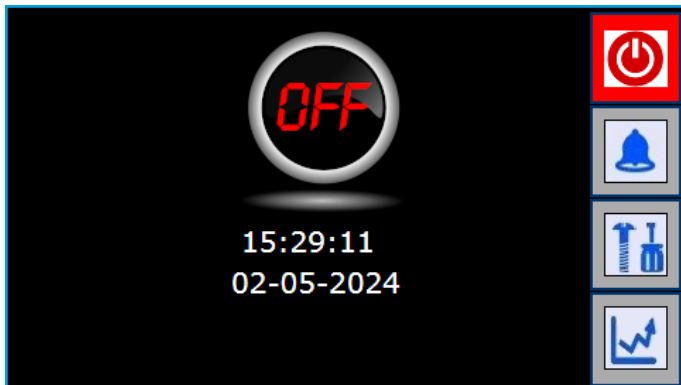

5.10.3 CONTROLLER DISPLAY SCREENS

INITIALIZATION: STANDBY (Start screen - OFF position):

Screen appears briefly when electrical power is initially supplied to the dryer.



Screen icons description

	ON/OFF icon: press to start dryer and pass to HOME page. The Icon is RED if OFF , GREEN if ON
	ALARM/WARNINGS icon. The Icon is RED if ALARM, YELLOW if WARNING .Press the Icon to go to the ALARM or WARNING page
	SETTINGS Icon. Press it to pass to the SETTINGS submenu
	N/A

DRYER ON position: (ON/OFF icon is GREEN) 
 Dryer starts as STEP 2 - Pressurisation of L&R tower.

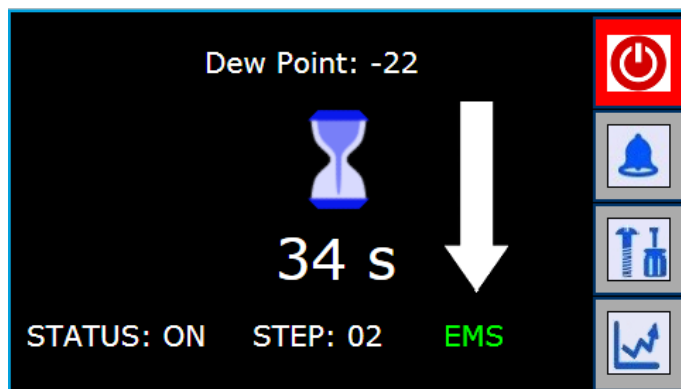

OPERATING STATUS:

Screen appears after ON/OFF icon (green once it is in ON-operation) has been touched.

Screen indicates:

- STATUS: ON or OFF position
- L/R tower Drying/Regenerating status: (Arrows will switch at time of tower changeover)

- Drying Operation Cycle: arrow pointing upwards
- Regeneration Operation Cycle: the arrow is flashing and pointing downwards
- STEP information number (4 steps available. Drying/Regenerating, pressurisation,EMS...)
- TIME counting down to finish current step
- ALARM status (See section below)
- Pressure Dew Point value at dryer outlet during operation (IF Dryer is equipped with EMS option)

NOTE: If the dryer is switched OFF and user try to switch ON again in short time period, a hourglass appears to show the remaining waiting time. Total time for this function is 30s.

ALARM SUBMENU:

Touch ALARM icon  to see alarm status of dryer:
 Screen indicates ALARM STATUS

- **NO ALARM**

NO warning screen. Press  to go back to HOME page.



- **DRYER IN ALARM:**

Alarm present. The list of the last 10 alarms can be seen in ALARM LOG inside the SETTINGS submenu.

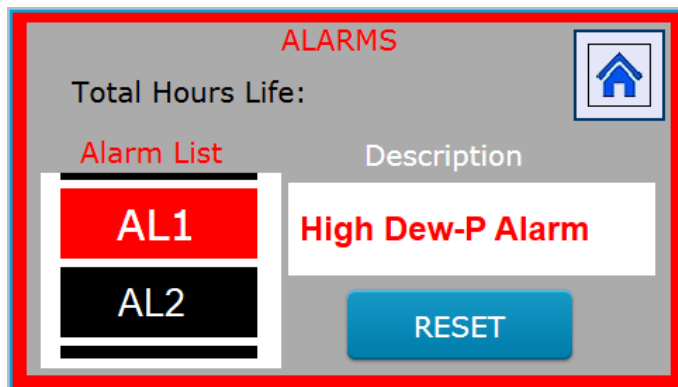

Press  to go back to HOME page.

To clear alarm, press RESET Icon .





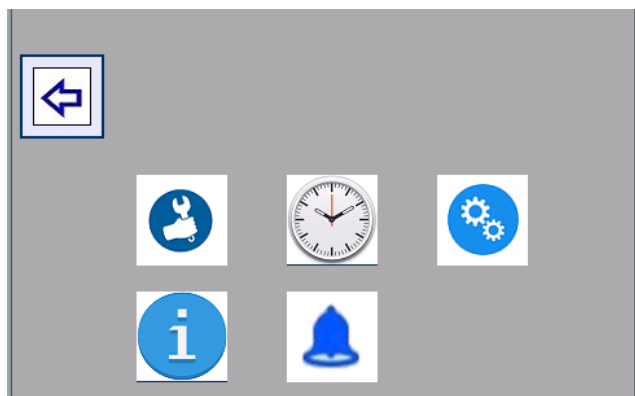

NOTE: See list of the latest 10 alarms in section SETTINGS below.

5.0 PRINCIPLES OF OPERATION

SETTINGS SUBMENU: Touch icon :

Screen indicate:



	Go back to HOME screen
	Go to SERVICE screen. (Available with password only)
	Go to Clock and Date settings page
	Go to PARAMETER settings screen
	Go to INFORMATION screen
	Go to ALARMS LOG screen

• **SERVICE window:** Touch icon :

Function password protected. Serves to show Total Hours Life and maintenance schedule time remaining.

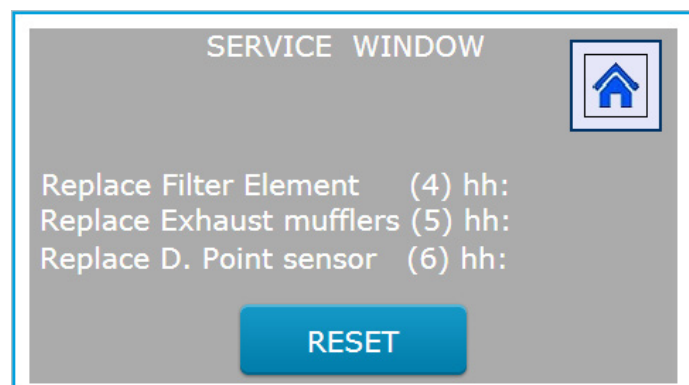

To enter into service screen password should be inserted using available keyboard (please select number availability).

PW: 4040

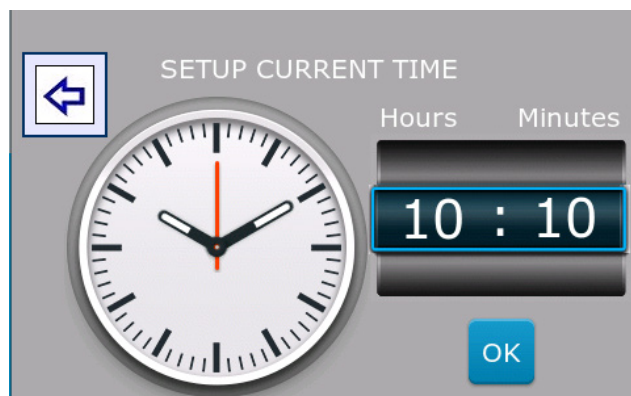

• **CURRENT TIME setup window:** Touch icon :



Set current time by scrolling Hours and Minutes values. To set current time, touch icon  to set current date by scrolling Day number, Month and Year. To set and save, touch icon  again.

• **PARAMETER SERVICE window:** Touch icon :

Function password protected. To enter into Parameters screen password should be inserted using available keyboard (please select number availability). PW: 2010

NOTE: Function to be used by properly skilled technician only. Setting wrong parameter could result in incorrect outlet compressed air values which can damage dryer and rest items in pneumatic line.

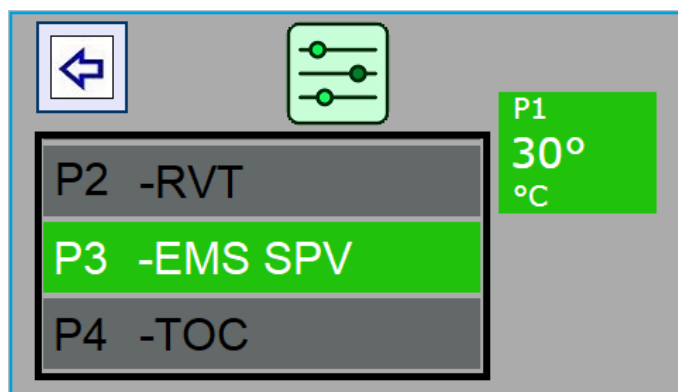

Description and each parameter available is shown in Parameter summary table below.

Icon EDIT serves to modify each parameter chosen on left side of screen. By touching icon - & + parameter can be scrolled. Touching icon SAVE, currently setted parameter and its value is saved.

5.0 PRINCIPLES OF OPERATION

Please see summary of all parameter in below table:

PARAMETER	DESCRIPTION
P1-PVT	Purge Valve Time
P2-RVT	Repressurization Valve Time
P3-EMS SPV	EMS SETPOINT Value
P4-TOC	Type of Control
P5-TRC	Type Remoto Control
P6-HDA	Alarm limit Hi PDP Alarm
P7-MA	Modbus Address
P8-BR	Baud Rate
P9-PDPT MAX	Dew point sensor MAX. value
P10-PDPT MIN	Dew point sensor MIN. value
P11-UOT	Units of Temperature
P12-EMS MAXT	EMS MAX. Time Limit
P13-DT	Dryer Type

- **INFORMATION window:** Touch icon 

Last version of Firmware is shown.

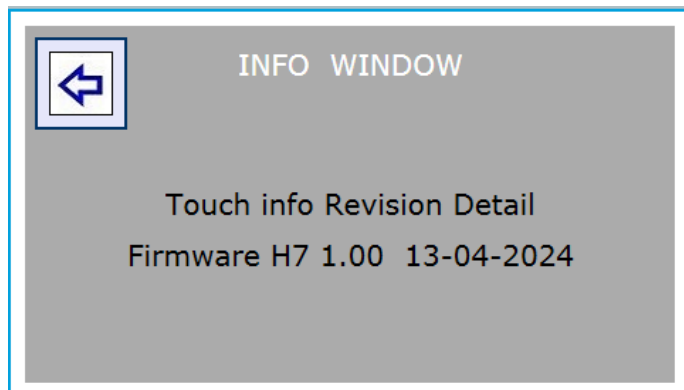

- **Alarm log window:** Touch icon 

Last ALARM and list of last 7 alarms with Description is shown.

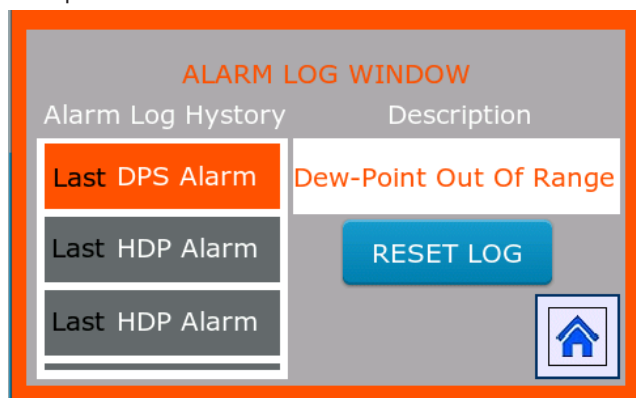

Press  to go back to HOME page.

To clear alarm, press RESET LOG Icon 

- **WRONG PASSWORD:** In case of password entered is wrong, customer will experienced screen below. Please touch back icon  to go back to home screen.

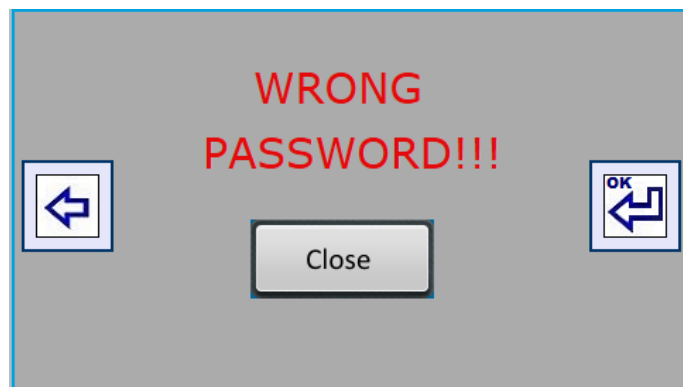

- **WARNING WINDOW:** Warning present. Please go to SERVICE screen in SETTINGS submenu so see the status of services.



6.0 INSTALLATION AND START-UP

6.1 APPLICATION AND CHECK ANALYSIS

To achieve the best dryer performance, you should carefully check that the design and installation requirements outlined below are satisfied.

NOTICE

The standard dryer is not rated for any gas other than air.

The dryer is designed to be operated with a compressed air inlet temperature ranging from 68°F (20°C) to up to 120°F (49°C) and at an operating pressure ranging from 60psig (4barg) to 200psig (14barg). The volume of air will be dependent on the system operating pressure. The air compressor delivering air to the dryer must be sized properly to handle both the demand and the purge air requirements necessary for regeneration.

The factory should be consulted if the dryer is to be operated at pressures below 60psig (4barg) to verify sizing and proper configuration.

The standard dryer is rated to operate at an inlet temperature and pressure of 100°F (30°C) @ 100psig (7barg). The operating conditions should be verified prior to installing and operating the dryer to ensure it is properly sized. A dryer with greater capacity may be required to achieve expected dew point performance in installations with elevated inlet air temperatures. Lower inlet temperature conditions may also reduce dryer performance.

It is important to note that delivering lower compressed air inlet temperature levels will reduce drying performance. A minimum compressed air inlet temperature of 68°F (20°C) is required to be supplied to the dryer for proper operation.

The dryer should generally be installed in an enclosed area where the ambient temperature does not drop below 50°F (10°C) and is not above 115°F (46°C). Please consult the factory for outdoor installation applications where additional provisions may be required for lower ambient conditions.

NOTICE

Hankison recommends the mufflers be cleaned after initial start-up to remove any desiccant dust generated during dryer shipment. After running the dryer for the initial 30 minute period, de-energize/depressurize the dryer and remove the mufflers. Disassemble and clean the removable insert inside the muffler core. Reinstall the mufflers prior to operating dryer. Periodic inspection of the mufflers is required to ensure proper dryer operation.

A minimum inlet temperature of 68°F (20°C) is required for proper dryer operation.

6.2 LOCATING AND MOUNTING

Use a forklift to lift the dryer only at the lift points identified with labeling. Use care to avoid damage to the manifold assembly. Bolt the dryer to the foundation using the bolt holes provided in the base frame. Anchor bolts should protrude a minimum of 1 inch (25 mm) above the foundation. Models HHM 5-HHM 25 can be wall mounted (See Figure 3). Use appropriate size bolts to hold entire dryer weight.

Figure: 3

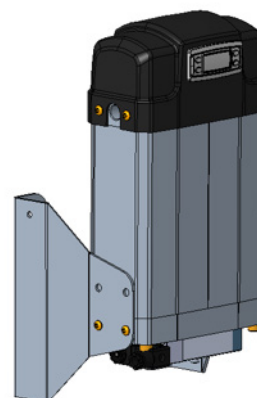

6.0 INSTALLATION AND START-UP

6.3 PIPING

Pipe the compressed air lines to the inlet and outlet connections. When installing the prefilters, the prefilters should be located as close to the dryer as possible. In addition, they should be positioned to allow for ease of service.

Note that the wet air inlet is at the dryer's lower manifold, while the dry air outlet is at the dryer's upper manifold. In situations where air supply is required 24 hours a day (where it is undesirable to interrupt the compressed air flow), an optional three valve by-pass system is recommended to bypass the dryer. To keep pressure drop at a minimum, the fewest elbows possible should be used. In order to prevent flooding of the desiccant bed when the dryer is off, the bypass should be used when troubleshooting the air compressor operation or when servicing the dryer.

Once all piping has been connected, all joints, including those on the dryer, should be soap bubble tested at line pressure to ensure no joints have been damaged in transit and during site placement. All installed piping must be self-supported. The dryer manifold piping cannot be used to support the interconnecting piping.

6.4 FILTRATION

Pre-filters and post-filters are not supplied with the dryers.

NOTICE

All model dryers must have proper filtration. Liquid water and oil must be removed before compressed air enters the dryer. Ensure Prefilters and drains are in good working order. Failure to do so will void warranty.

Prefilters should be located as close to the dryer as possible and must be provided with drains to prevent liquid water from entering the desiccant beds.

It is recommended that a mechanical separator with a properly functioning drain be installed immediately preceding the prefilter to remove bulk liquid and entrained water.

The particulate/coalescing afterfilter, located after the dryer, helps eliminate the possibility of desiccant dust carryover into the air system. To ensure proper dryer operation, the prefilter drain(s) must be inspected periodically.

The outlet filter on models HHM 5 - HHM 25 can be mounted on left or right outlet connection (See Figure 4) while the opposite connection must be plugged.

Figure: 4

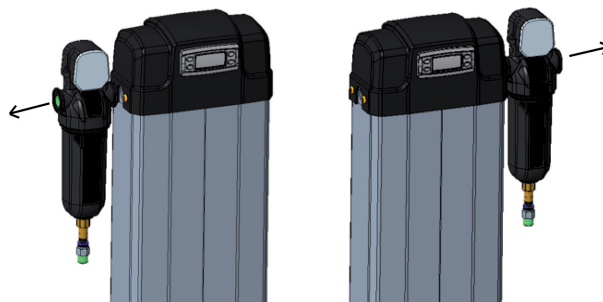

6.5 ELECTRICAL CONNECTION

Make all electrical connections to the dryer as shown on the wiring diagram (SECTION 9). Care must be taken to connect the proper voltages.

NOTICE

Dryer must be grounded with the full size ground wire connected to an earth ground.

NOTICE

Dryer must be fused according to NEC with the size fuse listed on the dryer serial nameplate, or on specification sheet in Technical Manual.

Size field connection knock-out for the conduit fitting required by the NEC. Installer must use UL Type 4 rated fitting.

The compressor interlock wiring should be verified if this function is to be activated at start-up.

6.6 DEW POINT MONITOR (EMS option)

EMS function should be connected with dryer outlet filter after post filter.

6.7 START-UP PROCEDURE

A Startup Form (included with the manual) must be completed and submitted with the Warranty Card as part of the commissioning process. This is included with the dryer at shipment.

Prior to pressurizing the compressed air system, conduct a visual inspection of the dryer to verify that the unit was not damaged during the installation process. This includes:

- Inlet and outlet compressed air piping connections are properly supported.
- Extruded pressure vessels are not damaged.
- Gauges are in good condition.
- Pneumatic control air hoses, inlet and outlet compressed air piping connections are properly supported and tightened.
- Prefilter and afterfilter bowl are properly tightened.

6.0 INSTALLATION AND START-UP

NOTICE

The Dew Point Transmitter that is supplied with the dryer as a separate component must not be installed until the dryer has been in operation for 24 hours.

After the visual inspection is complete, slowly pressurize the dryer and perform a verification check on the following items:

1. Verify that the air outlet shut-off valve is closed (if this is provided for the dryer). This can be provided as part of a three-valve bypass option for the dryer or field provided as part of the installation.
2. Check for air leakage prior to initiating flow through the dryer. Repair all leaks prior to starting the dryer. In order to maintain the drying performance of the dryer, any leaks must be fixed; most important are leaks identified on the outlet side of the dryer.

NOTICE

DO NOT FLOW COMPRESSED AIR THROUGH THE DRYER WHEN THE DRYER IS OFF. The desiccant beds will become flooded with moisture and the Warranty will be voided.

3. Verify that the prefilter drain is blowing freely to drain residual water in the system. If no moisture is observed exiting the drain, turn drain stem to the automatic position. Verify drains ahead of dryer are functioning properly.
4. Turn the field disconnect switch to the ON position to apply power to the dryer. This will energize the controller. Use proper PPE to verify that the voltage to the control panel matches the voltage/phase listed on the serial plate of the dryer. Do not apply power to the dryer until items 1-4 listed above have been verified. Do not apply power to the dryer or activate the dryer for operation until the air system checks are completed.
 - For dryers equipped with the EMS option, do not install the dew point transmitter until the dryer has operated for a minimum of 24 hours to reach steady state conditions. See the Warning note regarding installation of the dew point transmitter. Failure to follow this procedure will damage the dew point sensor and will void the sensor warranty.

5. The control air regulator located inside the top cover is preset to not exceed 100psig (7bar). The main flow inlet and purge valves are regulated to operate with a control air pressure level not to exceed 145psig (10bar).
6. Press the ON screen icon on the dryer controller to initiate dryer operation.
 - Observe the operation of the dryer and verify that the dryer sequence is operating properly. The dryer controller will automatically sequence the valves. Do not allow the dryer to operate if problems are observed.
 - Slowly open the outlet air shut-off valve (if equipped) and allow the system to slowly pressurize.
7. Verify that the compressed air system remains pressurized.

NOTICE

At initial start-up, check the dryer operation for one or two cycles, especially at the time of the tower shift. Verify that all systems are operating in their proper order and sequence. If the dryer is not functioning properly, contact distributor or Hankison Technical Service.

8. Verify the Technician and Maintenance settings of the dryer. Refer to SECTION 5.10 for further instructions.
 - Verify that the drain(s) on the inlet filters are operating properly. It is important to note that debris from the system piping may interfere with the operation of the float drain and it is the responsibility of the installer to verify this after the dryer is placed into operation. Drain maintenance or cleaning of system debris is not covered under warranty. Improper drain maintenance will result in damage to the desiccant beds and will void the warranty.
 - Once the system has operated for approximately two hours, the mufflers will need to be inspected. Follow proper safety procedures prior to replacing the mufflers. Mufflers are consumable items and are not warranted other than for manufacturing defects.
 - Monitor the operation of the dryer and contact **Hankison** if any problems arise during the startup process. The float drains on the dryer's should be inspected daily to ensure proper operation.

6.0 INSTALLATION AND START-UP

- For dryers equipped with the EMS option, install the dew point transmitter once the dryer has operated for a minimum of 24 hours and the BMI is fully blue in color. After the sensor has been installed, re-activate the EMS function through the settings screen.
- Verify (if wired) compressor interlock Function. See SECTION 5.8.

9. Complete the warranty startup card after the dryer is fully commissioned.

Long-Term Storage

If a dryer has been in storage for an extended period of time, follow the instructions above to start the dryer. Depending on the amount of time the unit was in storage, it may take between 8 and 12 hours before dryer would be regenerated.

NOTICE

When opening the outlet valve, ensure drying tower gauge maintains line pressure. Allowing the pressure in the dryer to drop will result in an overflow condition and potentially cause valves to stop functioning.

NOTICE

-100°F (-70°C) dryers require flow through the dryer to lower the pressure dew point to design levels. Failure to permit air flow through dryer (deadheading) will result in elevated outlet dew points. Once air is permitted to flow through the dryer, the pressure dew point will gradually reduce to design levels.

6.8 DRYER SHUT-DOWN SEQUENCE

The following procedures must be followed to correctly terminate dryer operation:

NOTE: The Dryer must remain pressurized during the shut-down sequence.

- Press the red “OFF” screen icon to deactivate the dryer operating sequence and de-energize the control valves. The main flow valves will be positioned to the default position:
 - a.The purge valve will close
 - b.The regenerating tower will re-pressurize
 - c.The main inlet flow valves will open

The system must remain pressurized in order for the main flow valves on the dryer to revert to the default position.

- The status line in the home screen will display “OFF” icon.
- The system will remain pressurized at all times. The dryer does not contain any provisions to permit a system bleed down.
- The red “OFF” screen icon only de-activates the dryer operating sequence electric power will remain live within the dryer main panel.

WARNING

Failure to follow this procedure may result in the system retaining pressure within the dryer and potentially result in an unsafe condition for service personnel.

NOTICE

DO NOT FLOW COMPRESSED AIR THROUGH THE DRYER WHEN THE DRYER IS OFF. The desiccant beds will become flooded with moisture. The dryer Warranty will be void.

7.0 MAINTENANCE AND SYSTEM CHECK

7.1 SCHEDULED MAINTENANCE

DAILY MAINTENANCE FUNCTIONS:

- Check and record inlet pressure, temperature and flow. Verify that it is within specifications.
- Check tower pressure gauge readings are within operating tolerance (HHM 40 - HHM 300 only).
- Check dryer operation for proper cycling, depressurization and re-pressurization.
- Check that the prefilter drain is operating properly and that there is no condensate discharged from purge mufflers.
- Verify that pressure in purging tower is 3psig (0.2barg) or less. If higher, muffler replacement is recommended. See SECTION 8.
- Check the dryer digital controller for alarms (HHM 40 -HHM 300 only).
- Verify that prefilter and afterfilter differential pressure is within operating limits. Replace elements / cartridges as specified by filter manufacturer.

MONTHLY MAINTENANCE FUNCTIONS:

- Check condition of mufflers by reading tower pressure gauge when the tower is in the regeneration cycle. If pressure is above 3psig (0.2barg), muffler replacement may be required.

NOTE: Hankison recommends the mufflers be cleaned after initial start-up to remove any desiccant dust generated during dryer shipment. After running the dryer for the initial 30 minute period, de-energize/depressurize the dryer and remove the mufflers. Disassemble and clean the removable insert inside the muffler core. Reinstall the mufflers prior to operating dryer. This procedure should be repeated within the first seven days of dryer operation.

SEMI-ANNUAL MAINTENANCE FUNCTIONS:

- Check outlet dew point (EMS option only).

ANNUAL MAINTENANCE FUNCTIONS:

- Check desiccant and replace if necessary.
- Inspect and clean pilot air control solenoid valves, check valves and flow valves. Rebuild and / or replace as required.
- Replace drains on prefilter and afterfilter.
- Test electrical components, replace as necessary.
- Check for loose electrical wiring connections and tighten as required.
- Check and replace mufflers
- Prefilter and Afterfilter elements / cartridges should be replaced according to the manufacturer's maintenance schedule.

EVERY THREE YEARS:

- Inspect pneumatic valves and replace angle valve bonnets if not functioning properly (Preventive). Check and replace shuttle valve assembly
- Replace control air solenoid valve (Preventive).
- Replace desiccant.

7.2 PREFILTERS AND AFTERFILTERS

NOTICE

All model dryers must have proper filtration. Liquid water and oil must be removed before compressed air enters the dryer. Ensure Prefilters and drains are in good working order. Failure to do so will void warranty.

PREFILTERS - The cartridges of the prefilter must be changed as often as required to prevent contamination of the regenerative dryer's desiccant bed.

The prefilter and automatic drain must be checked daily. To prolong filter cartridge life, it is recommended that a mechanical air/moisture separator be placed immediately before the prefilter.

AFTERFILTERS - The purpose of the afterfilter is to remove residual desiccant dust. Depending upon equipment application and usage, frequency of filter element change will vary. It is recommended that, at the minimum, the filter element be changed according to manufacturer maintenance schedule.

7.3 PILOT AIR CONTROL SOLENOID VALVES AND FILTER/REGULATOR

The length of time the pilot air valves can reliably operate without replacement is dependent upon the dryer operating cycle. On **Hankison** -40°F (-40°C) dew point dryers, replacing the valves every 36 months is recommended. For -100°F (-70°C) units, it is recommended that the pilot valves be replaced every 24 months. The control air regulator (See Figure 5) should be set for 100psig (7barg).

Figure: 5

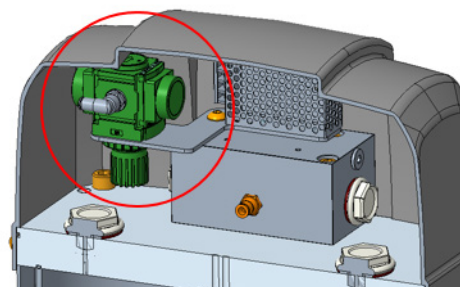

7.0 MAINTENANCE AND SYSTEM CHECK

7.4 MUFFLER CHANGEOUT PROCEDURE

⚠ WARNING

To avoid injury, depressurize dryer before performing any service.

- Stop dryer cyclic function.
- Depressurize the dryer. Disconnect dryer from electric power source.
- Replace mufflers.
- Follow Start-up Procedure described in SECTION 6.7.
- Turn control power back on.

7.5 ANGLE SEATED PURGE AND SWITCHING VALVES

- Purge Valves – Normally-Closed (N.C.) for purge air flow. Control air is supplied through tubing that is connected to the side port. When control air is supplied to the valve, a position indicator will extend from the top of the bonnet, indicating that the valve is open (See Figure 6).

Figure: 6

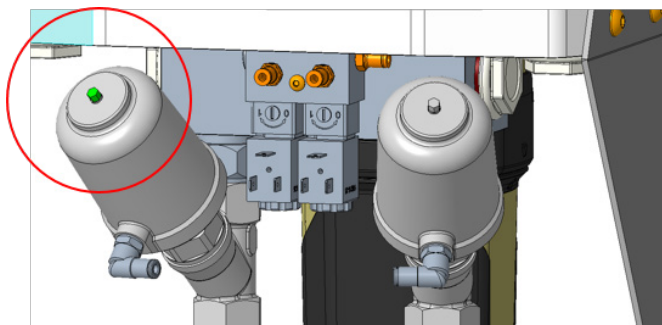

7.6 DESICCANT CHANGEOUT PROCEDURE

When it becomes necessary to replace the desiccant in the towers, observe the following procedure:

Units (HHM 40 - HHM 300) are furnished with fill and drain ports (See Figure 7) on each extruded tower. Remove the caps on both ports. Units (HHM 5 - HHM 25) are not equipped with drain ports, upper block cover needs to be taken off to change desiccant media

Figure: 7

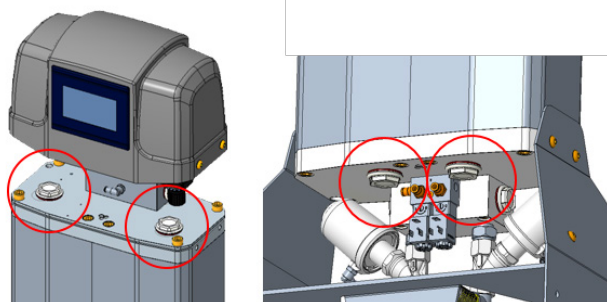

- To assist in getting the desiccant to flow from the tower, insert a small rod into the drain port as necessary. This may be required as the desiccant is packed into the towers which may interfere with the desiccant flow from the towers.
- With the fill port plug removed, fill the dryer tower with the appropriate grade and size desiccant.
- When the towers have been filled to the correct level, replace the fill port plug on each tower.
- Any connections and joints disturbed in the desiccant change out procedure should be leak tested prior to re-commissioning the dryer.

⚠ CAUTION

Desiccant will produce dust during the change out procedure. Be sure to wear respiratory protection during the draining and filling process to minimize inhalation of desiccant dust.

8.0 TROUBLESHOOTING

For troubleshooting procedures, refer to maintenance descriptions in SECTION 7 as required.

PROBLEM	PROBABLE CAUSE	CORRECTIVE ACTION
Elevated Dew-point	Insufficient purge flow	<ul style="list-style-type: none"> • Inspect purge valve & control air solenoid valves for proper operation. • Inspect mufflers for clogging.
	Improper valve operation	<ul style="list-style-type: none"> • Verify operation of main flow and purge valves. • Inspect control air solenoid valves for proper operation.
	Inlet air pressure below design condition	<ul style="list-style-type: none"> • Check pressure source and inspect piping system for leakages. • Verify that the dryer was sized appropriately for the operating conditions.
	Flow rate is higher than design condition	<ul style="list-style-type: none"> • Verify that compressor sizing is properly matched to dryer capacity. • For specialty systems where the outlet of the dryer is piped to a booster compressor, verify that the flow of the booster compressor is below the rated capacity of the dryer. Excessive flow will fluidize the desiccant bed and result in dusting and significantly reduce performance.
	Inlet temperature to the dryer exceeds the rated capacity of the dryer	<ul style="list-style-type: none"> • Inspect the air compressor after-cooler and drain to ensure proper operation. After-cooler may require cleaning in to operate properly. • Verify the inlet temperature does not exceed 120°F (50°C) under normal operating conditions. For applications that approach 120°F (50°C) on a continuous basis, dryer sizing should be reviewed prior to operation of the dryer. The standard design is rated based on an inlet condition of 100°F (38°C) @ 100psig (7barg) and will not deliver proper performance if it is undersized.
Excessive Pressure in Tower Designated For Regeneration (Above 3psig (0.2 barg))	Purge Muffler is clogged	Inspect purge mufflers for clogging and replace as required. Follow proper safety pre-cautions during this process.
	Air leak across purge muffler	Determine if inlet valves and outlet check valves are functioning properly.
Inability to Maintain Line Pressure On Drying Tower	Leaking check valve	Utilize valve function to determine if inlet and outlet valves are functioning properly.

9.0 WIRING DIAGRAM

9.1 HHM 5-HHM 25, ELECTRICAL SCHEMATIC

MODEL	POWER CORD LENGTH (m)
UMD5	2.0
UMD15	2.0
UMD25	2.0

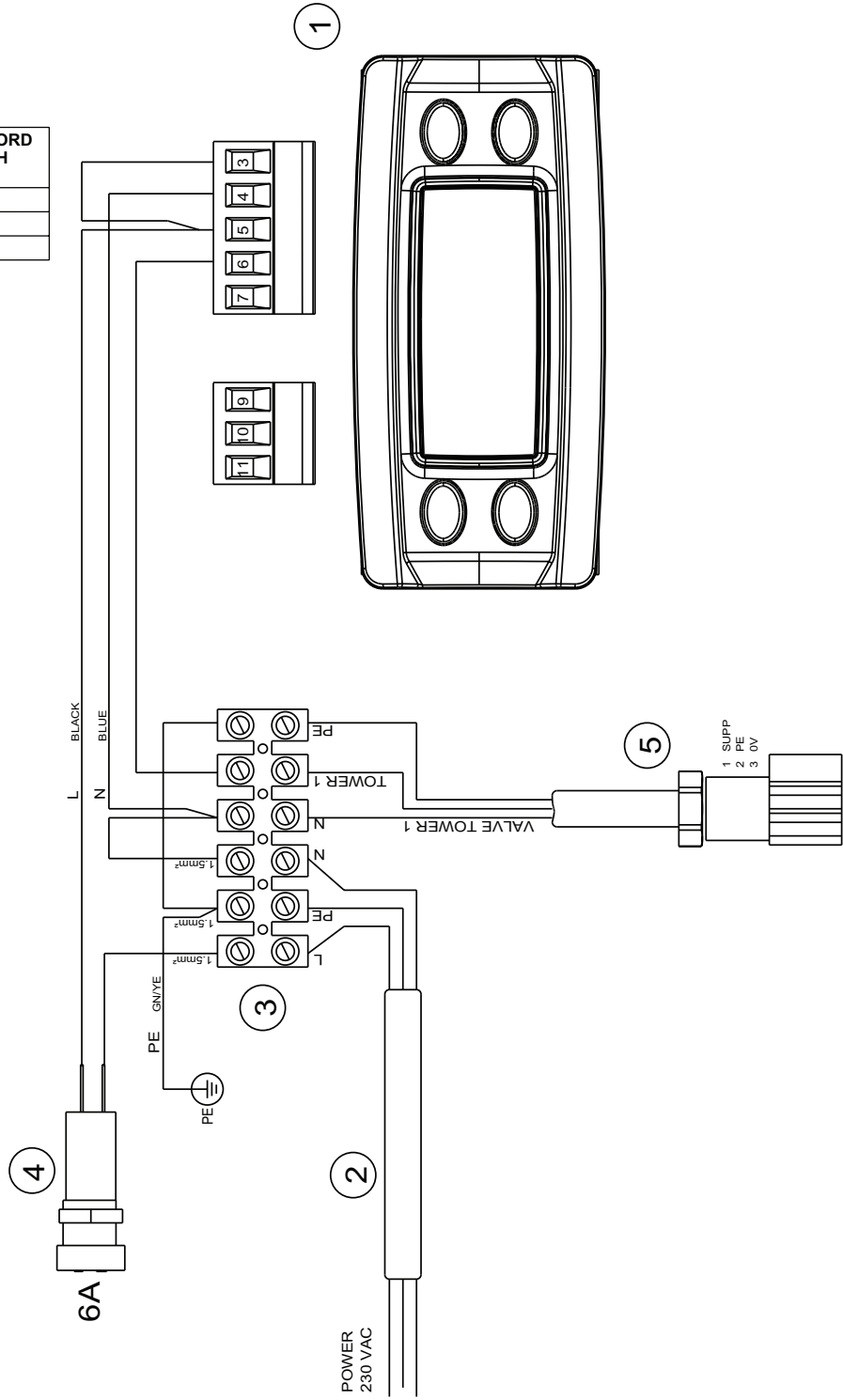

9.0 WIRING DIAGRAM

9.2 HHM 40-HHM 300, ELECTRICAL SCHEMATIC

MODEL	POWER CORD LENGTH (m)	WORKING CURRENT (AMP)
HHM 40	3.8	0.3
HHM 55	3.8	0.3
HHM 70	3.8	0.3
HHM 100	4.4	0.3
HHM 150	4.4	0.3
HHM 200	4.4	0.3
HHM 250	4.4	0.3
HHM 300	4.4	0.3

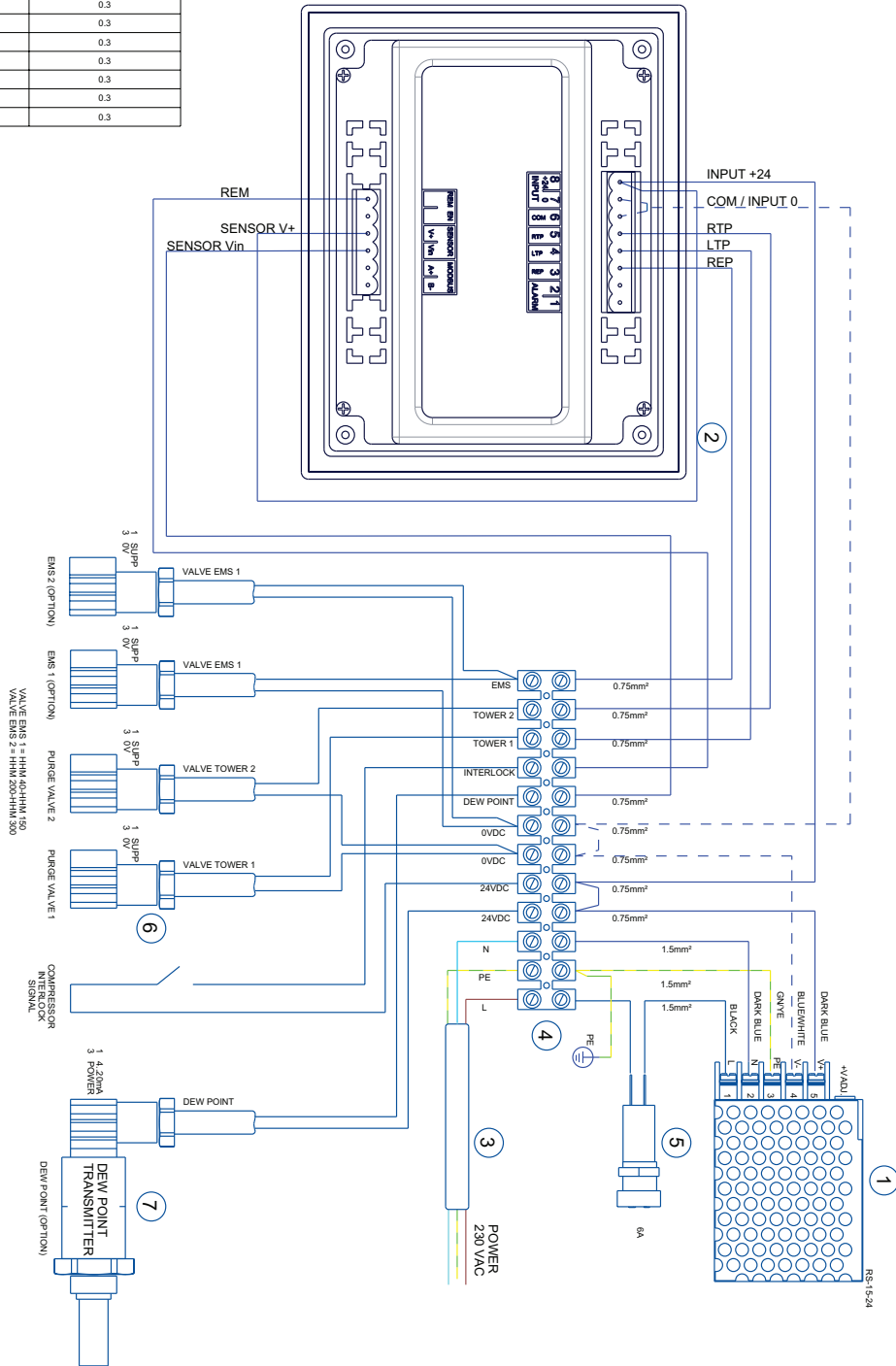

Pos.	DESCRIPTION	QTY.
1	POWER SUPPLY 230VAC, 24VDC 15W	1
2	PLC+HMI	1
3	CABLE 3 X 1.5 FLEX-JZ BLACK	SEE TABLE ON LEFT
4	TERMINAL BLOCK, 10x2,5mm ²	1
5	FUSE HOLDER	1
6	SOLENOID VALVE	3
7	DEW POINT	1

10.0 FLOW DIAGRAM

10.1 HHM 5 - HHM 25

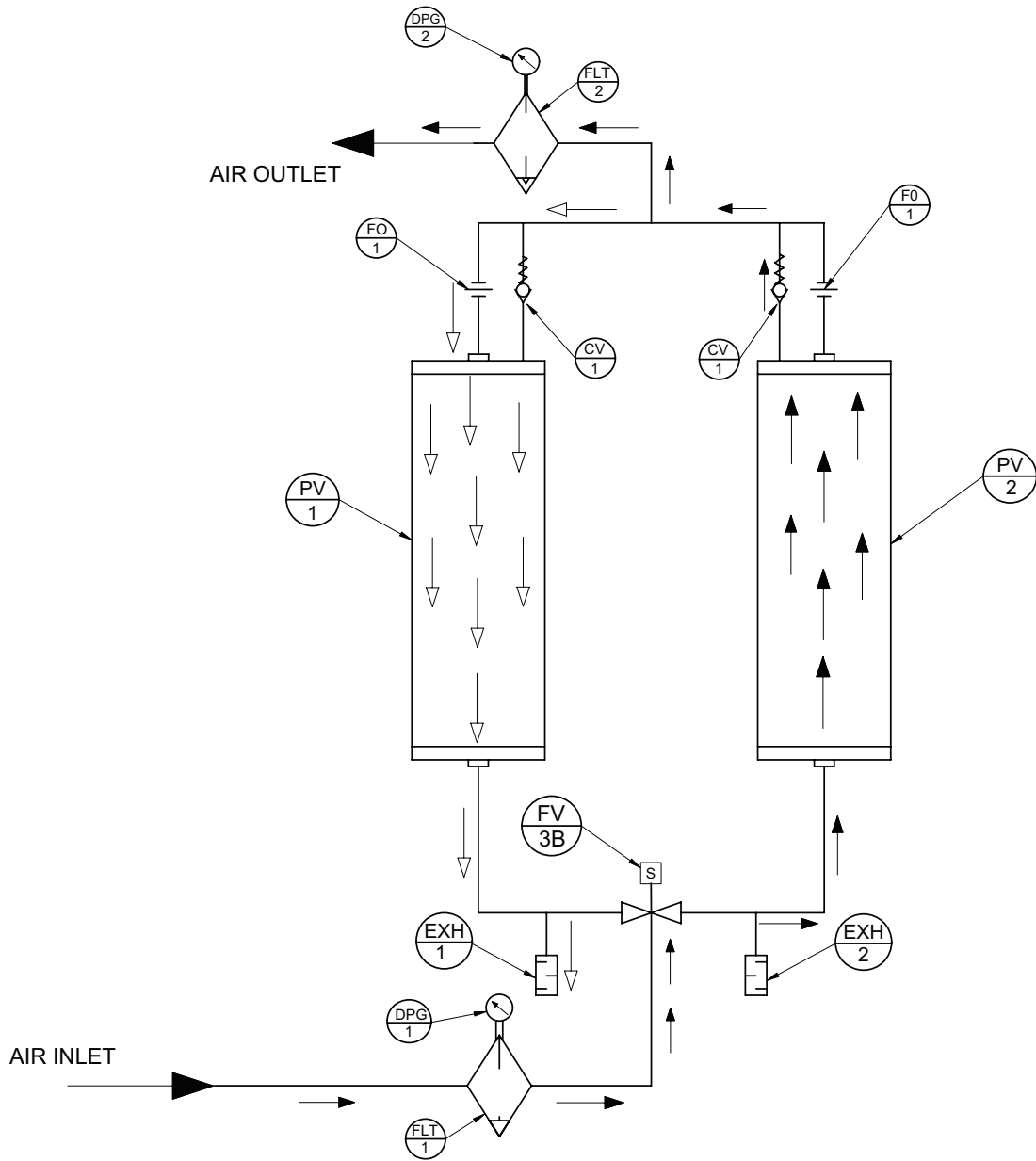

LEGEND:

- 1) PV-1: LEFT PRESSURE VESSEL
- 2) PV-2: RIGHT PRESSURE VESSEL
- 3) DPG-1: INLET DIFFERENTIAL PRESSURE INDICATOR
- 4) DPG-2: OUTLET DIFFERENTIAL PRESSURE INDICATOR
- 5) FLT-1: HIGH EFFICIENCY INLET PREFILTER
- 6) FLT-2: GENERAL PURPOSE AFTERFILTER
- 7) EXH-1: LEFT VESSEL PURGE MUFFLER
- 8) EXH-2: RIGHT VESSEL PURGE MUFFLER
- 9) FV-3B: LEFT & RIGHT VESSEL PURGE SOLENOID CONTROL VALVES
- 10) FO-1: PURGE ORIFICE
- 11) CV-1: NON RETURN CHECK VALVE

- : DRYING AIR FLOW
- : REGENERATING AIR FLOW
- : DRYER FLOW LINE

NOTE: Pre-filter(FLT-1)+(DPG1) and After-filter(FLT-2)+(DPG2) are not supplied with standard dryer package.

10.0 FLOW DIAGRAM

10.2 HHM 40-HHM 150

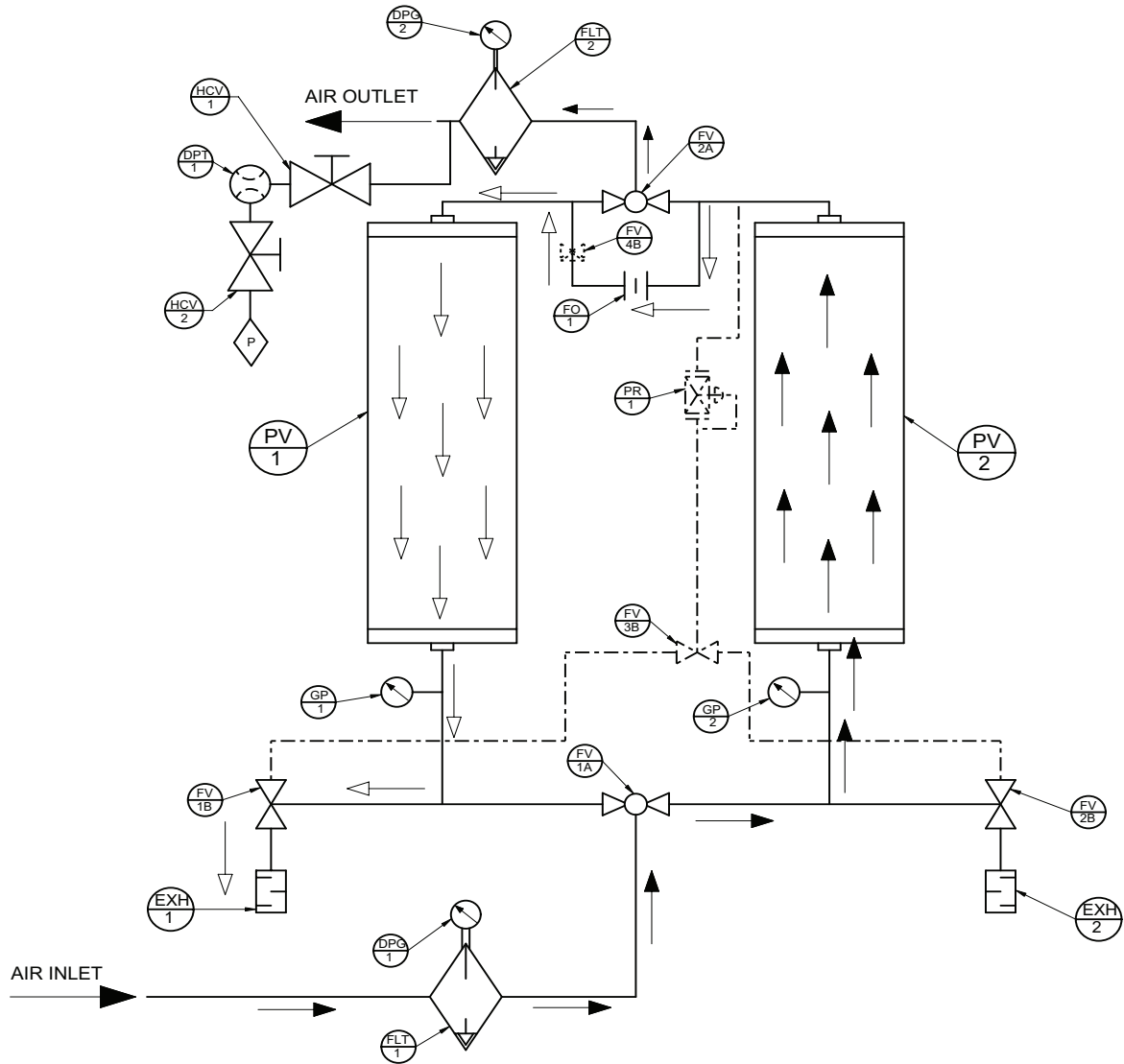

LEGEND:

- 1) PV-1: LEFT PRESSURE VESSEL
- 2) PV-2: RIGHT PRESSURE VESSEL
- 3) DPG-1: INLET DIFFERENTIAL PRESSURE INDICATOR
- 4) DPG-2: OUTLET DIFFERENTIAL PRESSURE INDICATOR
- 5) FLT-1: HIGH EFFICIENCY INLET PREFILTER
- 6) FLT-2: GENERAL PURPOSE AFTERFILTER
- 7) FV-1A: LEFT / RIGHT VESSEL INLET BALL VALVE
- 8) FV-2A: LEFT / RIGHT VESSEL OUTLET BALL VALVE
- 9) FV-1B: LEFT VESSEL PURGE NC PNEUMATIC VALVE
- 10) FV-2B: RIGHT VESSEL PURGE NC PNEUMATIC VALVE
- 11) EXH-1: LEFT VESSEL PURGE MUFFLER
- 12) EXH-2: RIGHT VESSEL PURGE MUFFLER
- 13) FV-3B: LEFT & RIGHT VESSEL PURGE SOLENOID CONTROL VALVES
- 14) FV-4B: EMS CONTROLLING VALVE (OPTIONAL)
- 15) FO-1: PURGE ORIFICE
- 16) PR-1: PRESSURE REGULATOR
- 17) GP-1: LEFT VESSEL PRESSURE GAUGE
- 18) GP-2: RIGHT VESSEL PRESSURE GAUGE
- 19) HCV-1: EMS TRANSMITTER SHUT-OFF VALVE (OPTIONAL)
- 20) HCV-2: EMS BLEED VALVE (OPTIONAL)
- 21) DPT-1: DEW POINT TRANSMITTER (OPTIONAL)

- : DRYING AIR FLOW
- : REGENERATING AIR FLOW
- : DRYER FLOW LINE
- : CONTROL FLOW / AIR LINE
- : OPTIONAL LINE

NOTE: Pre-filter(FLT-1)+(DPG1) and After-filter(FLT-2)+(DPG2) are not supplied with standard dryer package.

10.0 FLOW DIAGRAM

10.3 HHM 200-HHM 300

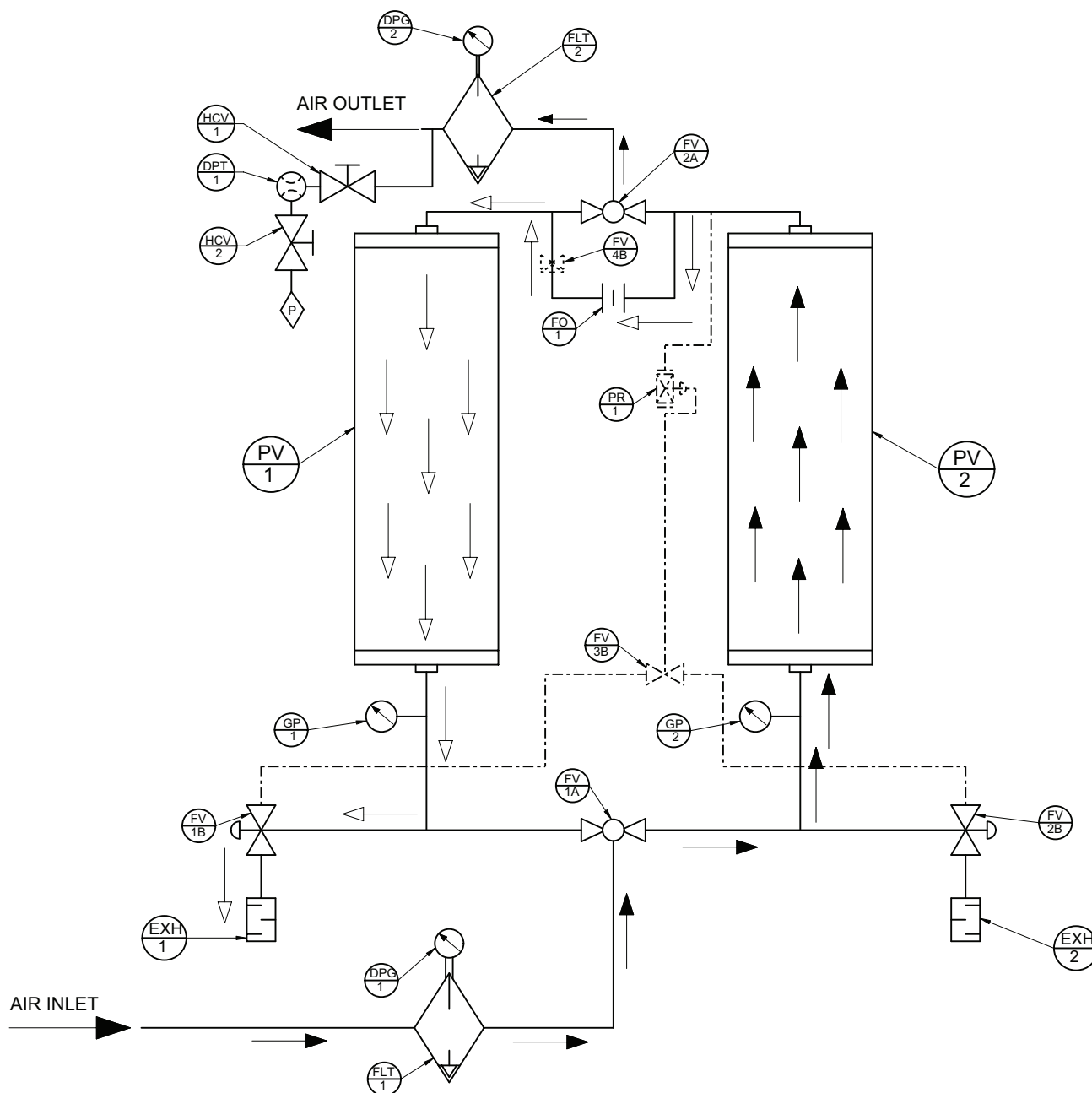

LEGEND:

- 1) PV-1: LEFT PRESSURE VESSEL
- 2) PV-2: RIGHT PRESSURE VESSEL
- 3) DPG-1: INLET DIFFERENTIAL PRESSURE INDICATOR
- 4) DPG-2: OUTLET DIFFERENTIAL PRESSURE INDICATOR
- 5) FLT-1: HIGH EFFICIENCY INLET PREFILTER
- 6) FLT-2: GENERAL PURPOSE AFTERFILTER
- 7) FV-1A: LEFT / RIGHT VESSEL INLET BALL VALVE
- 8) FV-2A: LEFT / RIGHT VESSEL OUTLET BALL VALVE
- 9) FV-1B: LEFT VESSEL PURGE NC PNEUMATIC VALVE
- 10) FV-2B: RIGHT VESSEL PURGE NC PNEUMATIC VALVE
- 11) EXH-1: LEFT VESSEL PURGE MUFFLER
- 12) EXH-2: RIGHT VESSEL PURGE MUFFLER
- 13) FV-3B: LEFT & RIGHT VESSEL PURGE SOLENOID
- CONTROL VALVES
- 14) FV-4B: EMS CONTROLLING VALVE (OPTIONAL)
- 15) FO-1: PURGE ORIFICE
- 16) PR-1: PRESSURE REGULATOR
- 17) GP-1: LEFT VESSEL PRESSURE GAUGE
- 18) GP-2: RIGHT VESSEL PRESSURE GAUGE
- 19) HCV-1: EMS TRANSMITTER SHUT-OFF VALVE (OPTIONAL)
- 20) HCV-2: EMS BLEED VALVE (OPTIONAL)
- 21) DPT-1: DEW POINT TRANSMITTER (OPTIONAL)

- : DRYING AIR FLOW
- : REGENERATING AIR FLOW
- : DRYER FLOW LINE
- : CONTROL FLOW / AIR LINE
- : OPTIONAL LINE

NOTE: Pre-filter(FLT-1)+(DPG1) and After-filter(FLT-2)+(DPG2) are not supplied with standard dryer package.

11.0 ANGLE VALVE REBUILD PARTS

VALVE PART NUMBER	VALVE DESCRIPTION	REPLACEMENT ACTUATOR PART NUMBER (CALLOUT 1)	SEAL REBUILD KIT* PART NUMBER (CALLOUT 2)	MOUNTING TOOLS
47846704001	VALVE, ANGLE, 3/4" P.O.N.C.	17933402	17933394	17933411
47846703001	VALVE, ANGLE, 1/2" P.O.N.C.	47682457001	47682458001	17933411

*Seal Rebuild Kit includes: Seat Seal, Head Section Seal, Exterior Lip Seal

Mounting tool is required for normally-closed valves (P.O.N.C.) only. Tool is required to decompress springs and is required for safe dismantling of the valve.

Tool is needed to install Replacement Actuator, as well as to install Seal Rebuild kit.

Normally Closed Valve

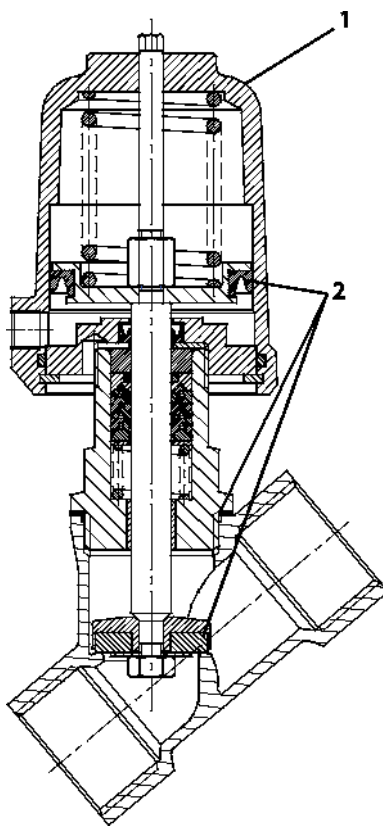

12.0 ENGINEERING SPECIFICATIONS

12.1 ENGINEERING DATA (-40°C)

	HHM 5	HHM 15	HHM 25	HHM 40	HHM 55	HHM 70
(-40°C) Inlet Capacity (m³/h)	5	15	25	40	55	70
Purge (m³/h)	0.9	2.7	4.5	7.2	9.9	12.6
Desiccant per Tower (kg)	0.7	2.15	3	6.5	8.3	11
Electrical	230/1/50-60	230/1/50-60	230/1/50-60	230/1/50-60	230/1/50-60	230/1/50-60
Air In/Out Connections BSPP	3/8"	3/8"	3/8"	3/4"	3/4"	3/4"
C -Width (mm)	238	238	238	475	475	475
B -Depth (mm)	212	212	212	365	365	365
A -Height (mm)	423	823	1073	968	1118	1318
Weight (kg)	9	16	21	46	55	62
Working current (AMP)	0.1	0.1	0.1	0.3	0.3	0.3

	HHM 100	HHM 150	HHM 200	HHM 250	HHM 300
(-40°C) Inlet Capacity (m³/h)	100	150	200	250	300
Purge (m³/h)	18	27	36	45	54
Desiccant per Tower (kg)	15.5	18	30.8	36	36
Electrical	230/1/50-60	230/1/50-60	230/1/50-60	230/1/50-60	230/1/50-60
Air In/Out Connections BSPP	1"	1"	1.5"	1.5"	1.5"
C -Width (mm)	475	475	536	536	536
B -Depth (mm)	365	365	495	495	495
A -Height (mm)	1673	1873	1705	1905	1905
Weight (kg)	82	86	160	180	180
Working current (AMP)	0.3	0.3	0.3	0.3	0.3

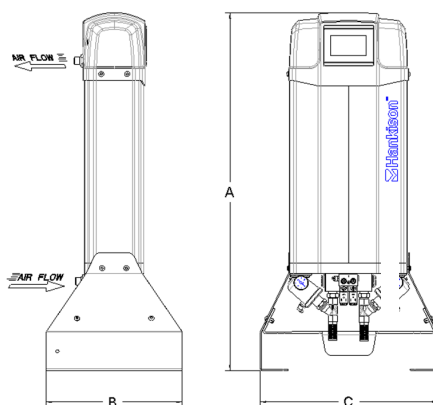

NOTICE

Specification information above accurate at time of publication. Refer to equipment serial label for actual specifications for units.

12.0 ENGINEERING SPECIFICATIONS

12.2 ENGINEERING DATA (-70°C)

	HHM 40	HHM 55	HHM 70	HHM 100	HHM 150
(-70°C) Inlet Capacity (m³/h)	32	44	56	80	120
Purge (m³/h)	5.76	7.92	10.08	14.4	21.6
Desiccant per Tower (kg)	6.5	8.3	11	15.5	18
Electrical	230/1/50-60	230/1/50-60	230/1/50-60	230/1/50-60	230/1/50-60
Air In/Out Connections BSP	3/4"	3/4"	3/4"	1"	1"
C -Width (mm)	475	475	475	475	475
B -Depth (mm)	365	365	365	365	365
A -Height (mm)	968	1118	1318	1673	1873
Weight (kg)	46	58	62	82	86
Working current (AMP)	0.3	0.3	0.3	0.3	0.3

	HHM 200	HHM 250	HHM 300
(-70°C) Inlet Capacity (m³/h)	160	200	240
Purge (m³/h)	28.8	36	43.2
Desiccant per Tower (kg)	30.8	36	36
Electrical	230/1/50-60	230/1/50-60	230/1/50-60
Air In/Out Connections BSP	1.5"	1.5"	1.5"
C -Width (mm)	536	536	536
B -Depth (mm)	495	495	495
A -Height (mm)	1705	1905	1905
Weight (kg)	160	180	180
Working current (AMP)	0.3	0.3	0.3

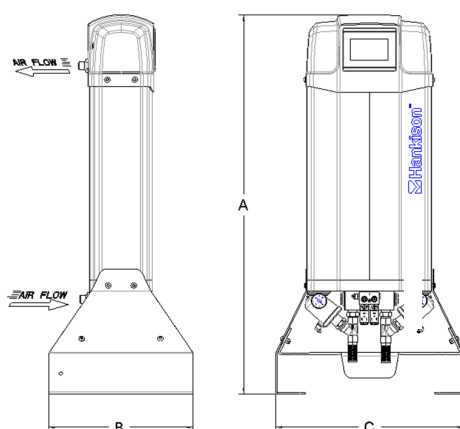

NOTICE

Specification information above accurate at time of publication. Refer to equipment serial label for actual specifications for units.

13.0 INTRODUCTION

DPC™ Controllers used on Desiccant dryers are configured with MODBUS capabilities. MODBUS enables the user to establish master-slave communications with any connected device that supports the MODBUS protocol. DPC™ currently supports RTU (binary) transmission mode.

The purpose of this guide is to provide the user with the methods used to interface with the DPC™ Controller, as well as specific addresses and commands that must be used to communicate with it. Given the diversity of communications systems in the marketplace, does not provide

intermediate programs or software to “bridge” the DPC™ Controller to any specific system.

However, using the information contained within this guide, the user may generate code to permit information within the DPC™ Controllers to be transmitted within a MODBUS-capable network.

14.0 MODBUS

MODBUS Configuration

The DPC™ Controller is preconfigured as a slave to accept MODBUS.

MODBUS Commands

Note: MODBUS operation should be limited to reading only memory bits and memory integer operands listed in Table 1.

DPC™ Controller Connections

The DPC™ controller offers only RS485 communication with the appropriate connection through the RS232 Serial Port to establish communications in conjunction with the appropriate communication protocol.

Figure: 8

RS485 port

RS485 connector signals

D+	Tx/Rx+ (B)
D-	Tx/Rx- (A)
T+	Positive Termination
T-	Negative Termination
SG	Signal Ground

Network Structure

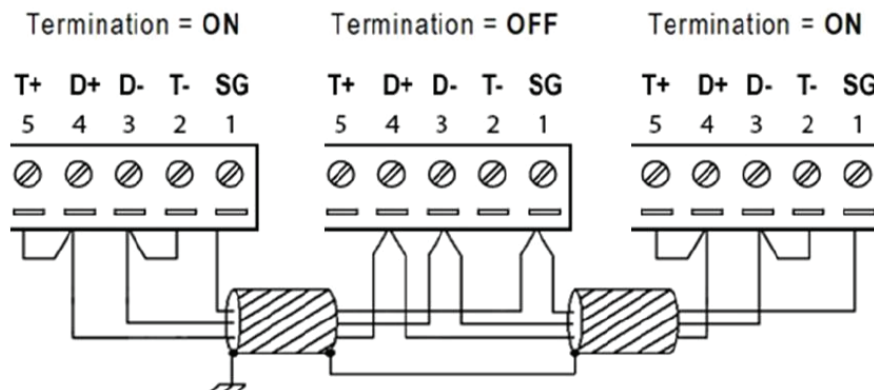

15.0 DESICCANT DRYER INFORMATION

The following table defines the Memory Bit and Memory Integer addresses for the various operations and alarms on the desiccant dryer.

Desiccant Dryer Information

The following table defines the Memory Integer and Memory bits addresses for the various operations and alarms on the desiccant dryer.

MI 100	Dryer Run Status 0=OFF 1=ON
MI 101	Step # [1-10]
MI 102	Step Time [counting down] [sec]
MI 103	Step Time Preset Length [sec]
MI 104	Units 0=C 1=F
MI 105	PDP Setpt C/F
MI 106	Mode Selected 0=time 1=EMS 2=compr intlk
MI 107	EMS Setpt C/F
MI 108	PDP Alarm Status 0=OFF 1=ON
MI 109	PDP Alarm Setpt
MI 110	Alarm Status 0=OFF 1=ON
MI 111	Alarm # [1-8]
MI 112	Restart Mode 0=Zero [& manual] 1=Last [& auto]
MI 113	Filter Element Days Elapsed
MI 114	Muffler Days Elapsed
MI 115	PDP Sensor Days Elapsed
MI 116	Valve Days Elapsed
MI 117	Desiccant Days Elapsed
MI 0	modbus address
MI 1	baud rate
MB 37	remote start
MB 38	remote stop



A series of horizontal lines for writing, consisting of 25 evenly spaced lines extending across the width of the page.



A series of horizontal lines for writing, consisting of 20 evenly spaced lines extending across the width of the page.

